

Type **TK17 H₂ 70 MPa**

WEH[®] Fueling nozzle for hydrogen fast filling

of cars at self-service fueling stations



General

DESCRIPTION



Features

- Type C nozzle acc. to SAE J2600 resp. ISO 17268
- Left or right single-handed operation
- Compatible with WEH® TN1 H₂ 70 MPa Receptacle profile
- WEH® EASY-TURN 250° swivel joint
- Easy operation
- High flow rate → short filling times
- Protection against impact and cold
- Plastic thermal protection
- Hand grip with magnet
- WEH® Jaw locking mechanism
- High-grade materials
- Coding for pressure range / gas type (acc. to table below)

The WEH® TK17 H₂ 70 MPa Fueling nozzle was developed for fast filling of cars with compressed, gaseous hydrogen (CGH₂). The fueling nozzle with single-handed operation is just as quick and easy to use as the common petrol nozzle and has a similar look and feel.

Simply lift the nozzle from the dispenser mounting and place it onto the vehicle's receptacle. The integrated swivel joint allows a free rotation of the coupling by approx. 250°. Then pull back the actuation lever and the refueling process can begin. The gaseous hydrogen only flows through the line if there is a safe connection. After the refueling process is completed, the fueling nozzle is disconnected by actuating the locking lever. Of course, refueling may be stopped or paused at any time. The hand grip has a magnet for actuation of the magnet switch for activation of the dispenser.

The internal coding for pressure range and gas type ensures that the TK17 H₂ 70 MPa can be connected to the compatible WEH® Receptacles acc. to the opposite table and also prevents the risk of confusion with natural gas.

The WEH® TK17 H₂ 70 MPa offers optimum safety for the operator thanks to the locking mechanism. The fueling nozzle remains connected to the receptacle until the locking mechanism is released by the operator.

Application

Fueling nozzle for hydrogen fast filling of cars at self-service fueling stations.

		TN1 H ₂			
		25 MPa	35 MPa	35 MPa HF*	70 MPa
TK17 H ₂ 70 MPa	70 MPa				✔

* HF = High-Flow

TECHNICAL DATA

Characteristics	Basic version
Nominal bore (DN)	4 mm
Pressure range	PN = 70 MPa PS = 87.5 MPa
Max. allowable operating pressure (when not connected)	PS = 50 MPa
Media temperature range	-40 °C up to +85 °C
Ambient temperature range	-40 °C up to +85 °C
Material	Corrosion resistant
Sealing material	Hydrogen resistant
Nozzle type	Type C acc. to SAE J2600:2015 and previous resp. ISO 17268:2012 and previous
Design	With plastic thermal protection, cold protection and hand grip with magnet
Weight	Approx. 1.9 kg
Conformity / Tests / Approvals	Tests acc. to SAE J2600:2002

Ordering / Accessories

ORDERING | WEH® TK17 H₂ 70 MPa Fueling nozzle

approx. dimensions (mm)

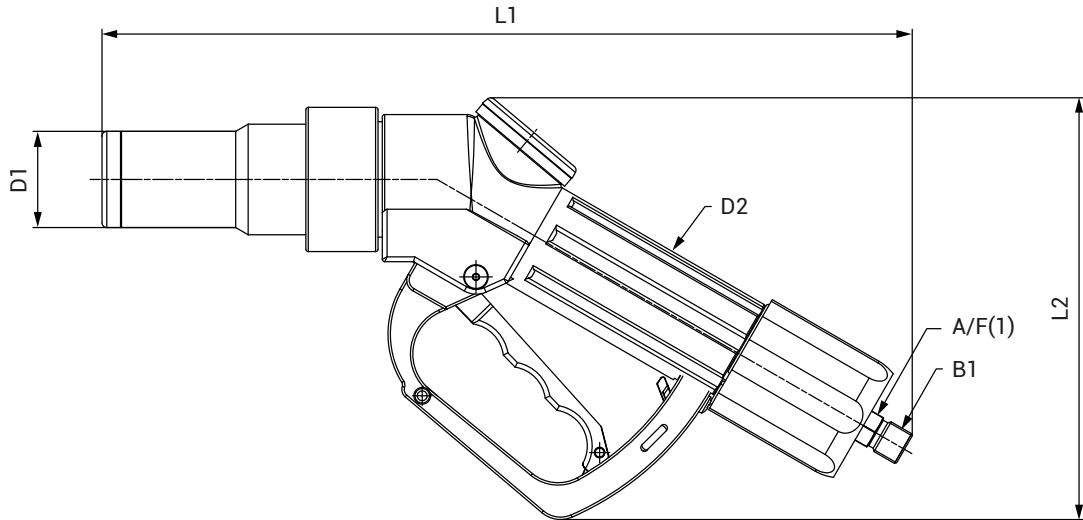

Part no.	Description	Pressure (PS)	B1 (male thread)	L1	L2	D1	D2	A/F(1)
C1-162708	TK17 H ₂ 70 MPa	87.5 MPa	UNF 9/16"-18*	337	175	40	46	14

* 60° inner cone

Fueling assemblies consisting of fueling nozzle, hose set and breakaway coupling are available on request.

ACCESSORIES

The following accessories are available for the WEH® TK17 H₂ 70 MPa Fueling nozzle:

Hose set

Hose set for connecting fueling nozzle and TSA1 H₂ 70 MPa breakaway coupling, complete with filling hose and braided protection hose as cover.

Design filling hose: max. operating pressure PS: 96.25 MPa / nominal bore (DN): 4.5 mm / media temperature range: -40 °C up to +85 °C



Part no.	B1/B2 (female thread)	Hose length
E68-163061	UNF 9/16"-18*	3 m
E68-163062	UNF 9/16"-18*	4 m
E68-163063	UNF 9/16"-18*	5 m

* DKJ 58°

Accessories

Dispenser mounting

Mounting for safe attachment of the fueling nozzle to the dispenser. Optionally a magnetic field sensor can be installed.

approx. dimensions (mm)

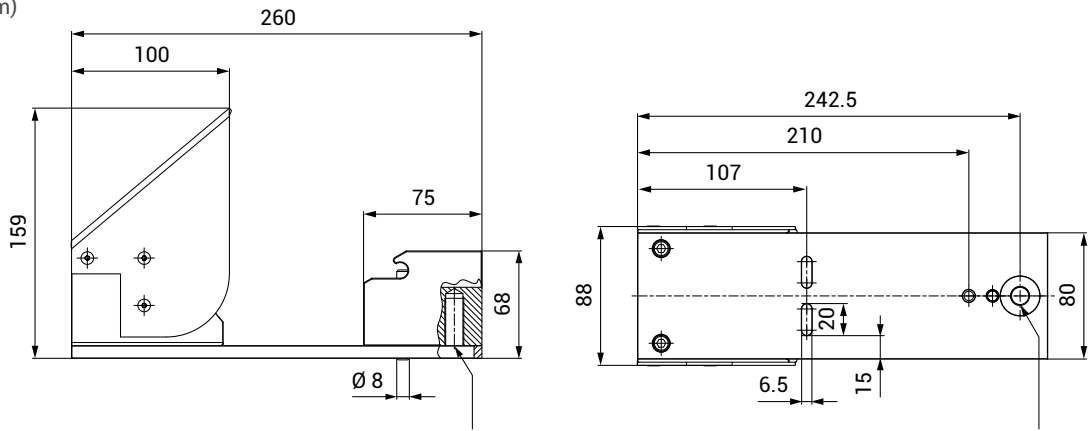

Mounting possibility for optionally available magnetic field sensor



Part no.	Description
C1-143641	Dispenser mounting (switch actuated) with weather protection and special cover for impact protection
E68-123980	Magnetic field sensor with 2 m cable, explosion-proof acc. to ATEX

WEH® TNS1 H₂ Service receptacle

To prevent damage in the fueling nozzle while purging or leak testing during maintenance in the course of which pressure is applied, we recommend the use of a service receptacle. The receptacle also protects the fueling nozzle from dirt ingress whilst not in use.



Part no.	Description
C1-148079	TNS1 H ₂ Service receptacle incl. protection cap

WEH® Breakaway coupling

For the suitable TSA1 H₂ 70 MPa breakaway coupling, please see page 35 in catalog no. 50.

Spare parts

SPARE PARTS

Various parts are available as spares for the WEH® TK17 H₂ 70 MPa Fueling nozzle.



Part No.	Description
E80-80187	1 Impact protection
E80-84030	2 Locking lever
E69-161748	3 Logo cap
E80-59738	3 Label plate
E80-162272	4 Plastic thermal protection (cold protection)
E99-44923	Maintenance spray

When ordering please specify the part no. engraved on the fueling nozzle.

Technical explanations

TECHNICAL EXPLANATIONS

Abbreviations/Definitions

For explanation of abbreviations and definitions of terms see applicable Technical Appendix of the corresponding catalog or www.weh.com

Illustrations

The illustrations and/or images used in these data sheet are particularly provided for illustrative purposes only and may differ in some details from the actual product. For binding information, please refer to your individual orders.

Safe product selection

Our WEH® Products are designed to be operated by qualified professional users (insofar as WEH® Products are also designed to be operated by other users in individual cases, this is explicitly stated in the corresponding operating instructions). Please note that WEH does not know your system and therefore - also due to the large number of different potential applications of WEH® Products - cannot perform tests on all potential types of application. You alone are responsible for the selection, configuration and suitability of WEH® Products, especially according to the requirements of your system. Before purchasing WEH® Products, please particularly ensure that our products are compatible with your intended use, your performance data, your material and fluids, your system concept and your system limits according to our product specifications. Please also consider your technical and legal requirements for operation, handling and maintenance. The quality and safety of WEH® Products is our highest priority. For this reason, WEH® Products may not be used outside the specifications in the relevant data sheets and product descriptions. If you are not sure whether the WEH® Product is suitable for your system and intended use, please contact us in advance. We also strongly recommend that you refrain from using third-party spare parts or a combination of WEH® Products with unsuitable third-party products. You alone are responsible for reviewing the suitability of third-party products. WEH® Products and WEH® Spare parts comply with our quality and safety standards.

Service life

WEH® Products are generally products which may be subject to wear and fatigue during operation and depending on your individual application/use. For details - in particular regarding the corresponding minimum inspection and maintenance intervals - please refer to the respective operating instructions for the WEH® Product.

Explanation on the Pressure Equipment Directive

These WEH® Products are generally classified as pressure accessories in accordance with Article 2 (5) of the Pressure Equipment Directive 2014/68/EU and are considered to be similar to piping. These WEH® Products may not be used as safety accessories. Furthermore, it is pointed out, that these WEH® Products are designed and placed on the market in accordance with the requirements of Article 4 (3) of the Pressure Equipment Directive 2014/68/EU. The assessment with regard to a different classification can, however, be made on request.

External change management

WEH reserves the right to update, optimise and adjust its products continuously. This may result in corresponding changes of the product. Customers will be informed proactively or unsolicited by WEH only in individual cases about product updates, product optimisations and/or product adaptations that have been carried out. You are free to contact WEH at any time to request information about any product updates, product optimisations and/or product adjustments.

© All rights reserved, WEH GmbH Verbindungstechnik.

Any unauthorized copying, distribution or other use of the copyrighted content is strictly forbidden without the written consent of WEH GmbH Verbindungstechnik.

Upon transmission of a newer version of this document, all previous versions are no longer valid. In principle, the latest version of the document is valid. This can be found at www.weh.com.

Our General Terms and Conditions and the Agreement on Protection of Know-How and Quality Assurance (www.weh.com) shall apply to deliveries and other services, unless expressly agreed otherwise.

We do not accept any General Terms and Conditions of the purchaser.

WEH® is a registered trademark of WEH GmbH Verbindungstechnik.

» Contact

More questions? – Great! Don't hesitate to contact our experts.

Manufacturer:

WEH GmbH Gas Technology

Josef-Henle-Str. 1

89257 Illertissen / Germany

Phone: +49 7303 95190-0

E-Mail: h2sales@weh.com

Website: www.weh.com